

Multi-Pure®

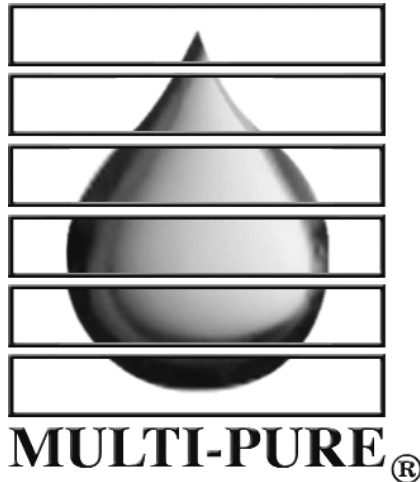

MULTI-PURE DRINKING WATER SYSTEMS
BELOW THE SINK AND COUNTERTOP

CB Series OWNER'S MANUAL

**For Model Nos. CB-As-SB, CB-As-SC, CB-As-SI, CB-As-SB-PID,
CB-VOC-SB, CB-VOC-SC, CB-VOC-SI, and CB-VOC-PID**

Multi-Pure Drinking Water Systems

Thank you for selecting a Multi-Pure Drinking Water System to meet your need for quality drinking water. You have acquired one of the finest drinking water treatment devices available for the reduction of a wide array of contaminants. We are confident that your Multi-Pure System will make a difference in your life. Thank you for your business.

Table of Contents

<p>I. General Information</p> <p>A. Warranty 3</p> <p>B. Operation & Maintenance Specifications 4</p> <p>C. Installation Overview & Parts 4-5</p> <p>II. Preparing the Housing</p> <p>A. installing the Filter 6</p> <p>III. Countertop Installations</p> <p>A. Connecting the Hose and Diverter Valve 6</p> <p>B. Start-up and Use of Your Countertop 7</p> <p>C. Filter Life 7</p> <p>IV. Below Sink Installations</p> <p>A. Required Tool List 8</p> <p>B. Attaching the Adapters 8</p> <p>C. Housing Assembly 9</p> <p>V. Installing the Faucet</p> <p>A. Drilling the Hole 10</p> <p>B. Installing Faucet 11</p> <p>C. Installing Faucet with Capacity Monitor 12-14</p>	<p>VI. Connecting to your Plumbing 14-15</p> <p>VII. Connecting the Drinking Water System</p> <p>A. Adapter Connection 16</p> <p>B. Tubing Connection 16</p> <p>C. Ice-Maker Connection 17</p> <p>D. Placing the System Under Your Sink 18</p> <p>E. Installing Inline Models 18</p> <p>VIII. Start-up and Use and Filter Life 19</p> <p>X. Performance Certification 20</p> <p>IX. Performance Data Sheets & California Certifications 21-28</p> <p>XI. Troubleshooting & Questions and Answers 29-30</p>
--	--

I.A WARRANTY

Multi-Pure Warranty: Multi-Pure Corporation warrants to the original retail customer its Drinking Water Systems and components to be free of defects in material and workmanship for use under normal care, and will repair or replace any System at no charge (excluding transportation to Multi-Pure headquarters) to the customer during the warranty period. The Drinking Water System housing is warranted for for a lifetime (provided that filter has been changed at least once per year); all exterior hoses and attachments to the System are also warranted for defects in material and workmanship for one year.

Multi-Pure Solid Carbon Block Filters are warranted for defects in material and workmanship for use under normal care. The capacity of the filter cartridge depends upon the amount of impurities in the water to be processed. For optimum performance and to maintain your warranty, it is essential that the filter be replaced when the first of the following occurs: (a) annually; (b) when the unit's rated capacity is reached; (c) the flow rate diminishes; (d) the filter becomes saturated with bad tastes and odors.

Except as otherwise expressly provided above, Multi-Pure Corporation makes no warranties, express or implied, arising by law or otherwise, including without limitation the implied warranties of merchantability and fitness for a particular purpose, to any person. This limited warranty may not be altered, varied or extended except by a written instrument executed by Multi-Pure Corporation. The remedy of repair or replacement as provided under this limited warranty is exclusive. In no event shall Multi-Pure Corporation be liable for any consequential or incidental damages to any person whether occasioned by negligence of the manufacturer, including without limitation damages of loss of use, cost of substitution, property damage, or other monetary loss.

Warranty is valid only if Drinking Water System is operated within conditions listed herein.

I.B Operation and Maintenance Specifications

	<u>CB-As-SX series</u>	<u>CB-VOC-Sx series</u>
Model Numbers in series	CB-As-SB, CB-As-SC, CB-As-SI, CB-As-SB-PID*	CB-VOC-SB, CB-VOC-SC, CB-VOC-SI, CB-VOC-PID*
Replacement Filter Type	CBTAs	CBTVOC
Approximate Filter Capacity	600 gallons	750 gallons
Capacity with End-of-life Indicator*	960 gallons	1200 gallons
Approximate Flow Rate @ 60 psi	1.0 gpm	.75 gpm
Housing Composition	Stainless Steel	Stainless Steel
Rubber Items	Nitrile	Nitrile
Inlet	1/4" NPTF x 1/4" tube	1/4" NPTF x 1/4" tube
Outlet	1/4" NPTF x 1/4" tube	1/4" NPTF x 1/4" tube
Maximum Working Pressure	100 psi/ 8.8 kg/cm ²	100 psi/ 8.8 kg/cm ²
Minimum Working Pressure	30 psi/ 2.1 kg/cm ²	30 psi/ 2.1 kg/cm ²
Maximum Operating Temperature	100° F/38°C for cold water use only	100° F/38°C for cold water use only
Minimum Operating Temperature	32°F/0°C for cold water use only	32°F/0°C for cold water use only
Particle Retention Size	sub micron (0.5 micron)	sub micron (0.5 micron)
Certified by:	NSF International	NSF International
* model comes with end-of-life indicator (PID)		

NOTES

1. Replacement filters can be purchased from your Dealer. Replacement filter model numbers are shown above.
2. Filter life will vary in proportion to the amount of water used and the level of impurities in the water being processed. Replace the filter cartridge when the first of the following occurs: (a) annually; (b) when the systems rated capacity is reached; (c) the flow rate diminishes; (d) the filter becomes saturated with bad tastes and odors. The rated capacity of the filter cartridges is shown above.
3. Model Nos. CB-As-SB-PID, and CB-VOC-SB-PID come with a capacity monitor that automatically flashes when it is time to replace the filter.
4. Not intended to be used where the water is microbiologically unsafe or with water of unknown quality without adequate disinfection before or after the unit. Systems certified for cyst reduction may be used on disinfected waters that may contain filterable cysts.
5. Do not allow water to freeze in the unit. If unit is exposed to freezing temperatures, drain water from unit and remove filter.
6. Do not allow water to sit in unit for extended periods of time (10 or more days) without being used. If unit is to be left unused for more than 10 days, drain all water from the system and remove the filter. Upon your return, reconnect the filter in the housing and continue use. In the event water does sit in the unit for 10 or more days, the system should be flushed by allowing water to flow to waste for about 3 minutes; then continue use as normal.
7. To dispose of the used filter, remove it from the housing and place the old filter in your normal refuse. The filter disposed of in a normal landfill will not release any chemical contamination but will probably continue to adsorb additional contaminants that are disposed of in landfills.

I.C INSTALLATION OVERVIEW & PARTS

Below Sink

Countertop

Item # Part Description

- 1 Faucet assembly with blue tubing attached
- 2 Wing nut
- 3 Clear tubing -connects inlet adapter to plumbing
- 4 Blue tubing -connects outlet adapter to plumbing
- 5 Inlet and Outlet adapters
- 6 Housing top
- 7 V-band
- 8 Black rubber cushion (inside housing top)
- 9 V-band knob
- 10 Carbon Block Filter
- 11 O-ring
- 12 Housing bottom
- 13 Acrylic sleeve (not shown)

Item # Part Description

- 1 Diverter valve assembly
- 2 Inlet and Outlet adapters
- 3 Housing top
- 4 Black rubber cushion (inside housing top)
- 5 V-band
- 6 V-band knob
- 7 Carbon Block Filter
- 8 O-ring
- 9 Housing bottom
- 10 Acrylic sleeve

(drawings are not to scale, actual parts may look different)

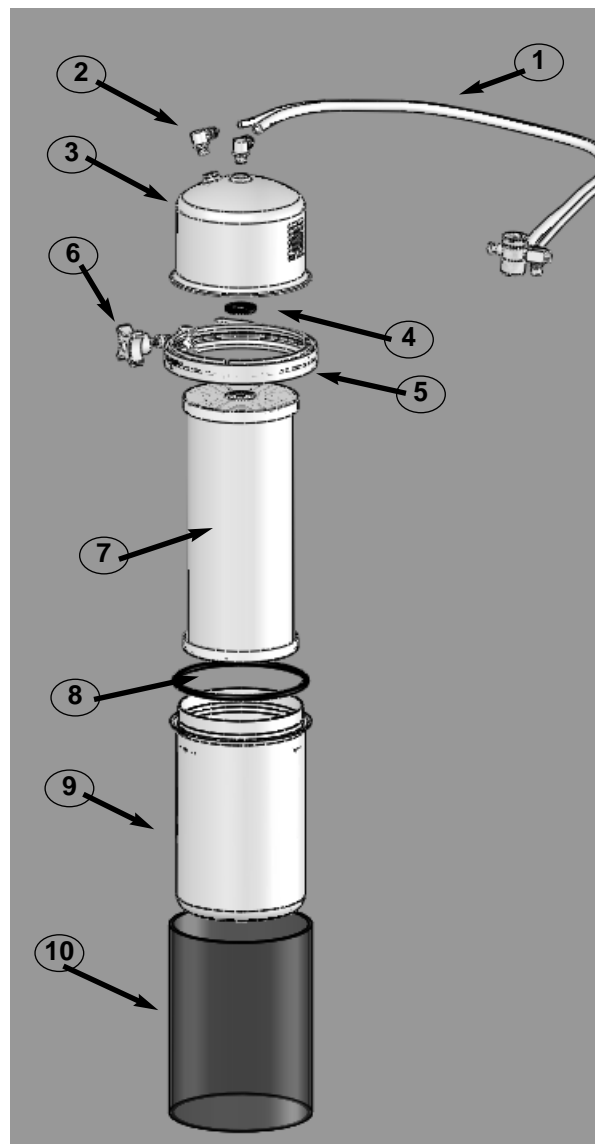
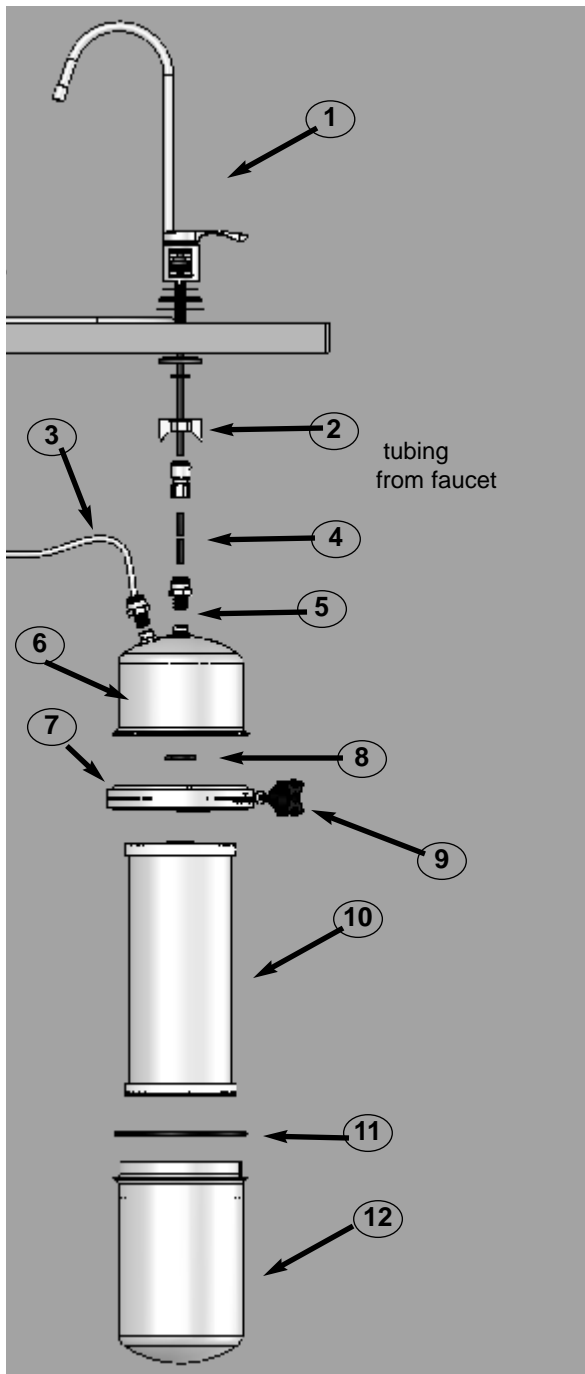

I.C INSTALLATION OVERVIEW (CONTINUED)

Multi-Pure Drinking Water Systems have been extensively tested and certified by independent agencies so as to provide you with the highest level of assurance that the device will perform as claimed. Please read this manual carefully before proceeding with the installation. Installation, operation and maintenance requirements are essential to the performance of your Drinking Water System. Failure to follow any instructions or operating parameters contained herein may lead to the product's failure and possible damage to property.

This owner's manual will help you install and use your Drinking Water System. Should you require assistance, please contact your Dealer/Representative.

Before installing your system, follow the below easy procedures to assure a smooth installation and system start up.

1. **Inspect your Drinking Water System to confirm that it has been received in good condition and that all parts are included.**
2. **Determine the system you will be installing and which installation procedures you will follow.**

II. PREPARING THE HOUSING

Countertop Models: All Multi-Pure Drinking Water Systems can be installed on the countertop next to your sink. For instructions on the countertop installation, please prepare the housing as outlined in this section and then proceed to Section III. Gather all tools recommended for the countertop installation before starting to install your system.

Below the Sink: Multi-Pure's Below Sink Models are designed for use below the sink. Your Below Sink Unit is shipped with an installation kit consisting of the accessories and fittings deemed appropriate for your area. Alternate accessories may be purchased at a minimal cost. For instructions on below sink installations, please prepare the housing as outlined under Section II and then proceed to Section IV. Gather all tools recommended for the below sink installation before starting to install your system.

II.A Filter Cartridge Installation

The filter cartridge is shipped outside of the unit housing (in most cases) to protect your filter and drinking water system from damage during shipping. Be sure to insert the filter cartridge into the drinking water system housing before proceeding with the installation.

First, remove the plastic wrapper and instruction wrap from around the filter.

Stainless Steel Units:

1. With the housing in an upright position, open the unit by unscrewing the black knob on the locking v-band. Spread it apart and remove the locking v-band.
2. Separate the unit, leaving the black rubber o-ring in place on the housing.
3. Screw the new filter (cartridge) in the housing top, turning the cartridge until firm. Be sure that the filter has been screwed in **STRAIGHT**. **DO NOT OVER TIGHTEN**.
4. Reconnect the housing top with bottom and replace locking v-band; replace black knob and turn until tight. Be sure that the locking v-band is fastened tightly by:
 - a. Checking the v-band to confirm that it is secured evenly around the housing top and bottom.
 - b. Hand-tightening the black knob on the v-band until it is as tight as possible.

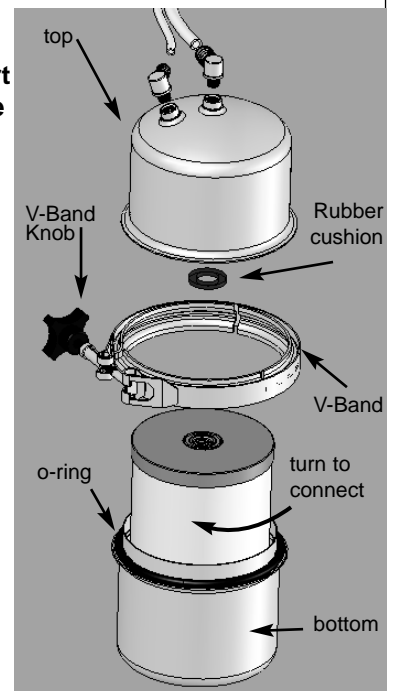

III. COUNTERTOP INSTALLATION

Countertop models sit on the counter next to the sink and are connected with a hose and diverter valve to your existing faucet. Your system comes with the hose and diverter valve connected to the housing. Be sure to read Section II before proceeding with the installation of your Countertop Drinking Water System.

III.A Connecting the Hose and Diverter Valve to Your Faucet

1. The water at your sink should be turned off.
2. Remove the aerator or screen from the end of your faucet.
3. Attach the Diverter Valve directly to the faucet spout. If the threads of the Diverter Valve don't match the threads of your faucet, use one of the adapters provided with your unit.
 - a. **Faucets with Outside Threads:** For most faucets with outside threads, the diverter valve can be attached directly to the faucet. However, if the Diverter Valve is smaller than your faucet, attach the adapter (MC106) with inside threads directly to your faucet and then attach the Diverter Valve to the adapter.
 - b. **Faucets with Inside Threads:** If your faucet has threads on the inside, attach one of the two adapters (MC107 or MC108) with outside threads (choose the appropriate size for your faucet) directly to your faucet and then attach the Diverter Valve to the adapter.
 - c. **Faucets with No Threads:** If your faucet has no threads, you will need to measure the inside neck diameter of the faucet and provide this information to your Multi-Pure Dealer. They will provide you with a special expandable adapter to fit your faucet in exchange for the adapters shipped with the unit.
 - d. **Faucets with Odd Sized Threads:** If your faucet does not fit any of the adapters provided with your unit, contact your dealer.
 - e. **Faucets requiring more clearance for the connection, such as sprayer hose faucets, would use a long adapter (MC257).**
4. Turn on the water and push the bypass lever of the diverter valve to start the flow of water through the unit. See next section for start-up and use of your drinking water system.



Model CB-VOC-SC

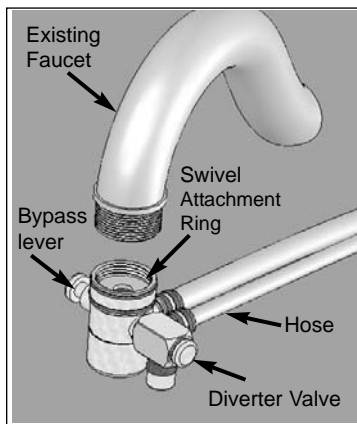

Diverter Valve Attachment

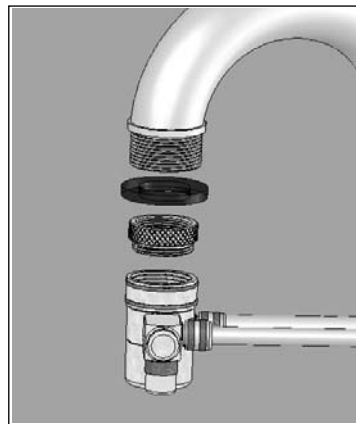

Diverter Valve Attachment
with adapter

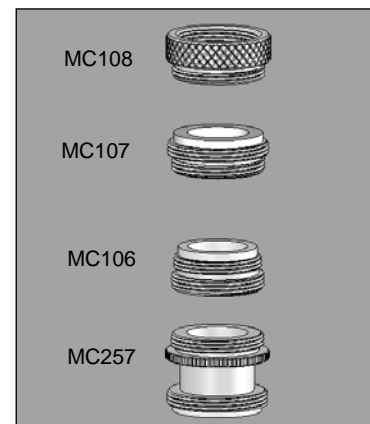

Adapters (choose one)
Many installations do not
require an adapter

III.B Start-up and Use of Your Countertop Drinking Water System

Congratulations, your Countertop Drinking Water System has been connected to your faucet and you are now ready to start-up the unit, as follows:

1. Using a paper towel or cloth, dry off all connections.
2. Also, dry off the drinking water unit.
3. Ensure that all connections are tight (CAUTION: DO NOT OVERTIGHTEN).
4. Turn on the COLD water only.
5. Push the bypass lever to start the flow of water through the unit.
6. Allow the water to run through the unit and out of the filtered water faucet for about 5 minutes so that all air can escape.
7. Push the bypass lever inward to shutoff the flow of water through the Drinking Water System. Then turn off the faucet to stop the flow of water at your sink.
8. Check all connections to confirm that there are no leaks.
 - a. Turn the unit upside down to allow any air trapped in stainless steel housing to escape.
9. Allow water to run through the filter to waste for approximately 30 minutes to flush the filter of loose carbon fines.
10. Push the bypass lever inward to shutoff the flow of water. Then shut off the water at your faucet and check for leaks.

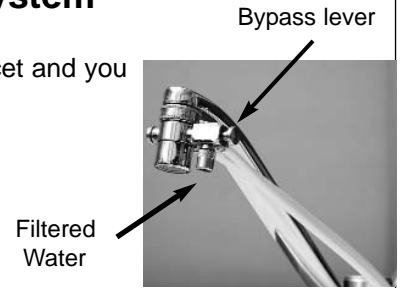

If you have any questions regarding the installation of your countertop unit, call your Multi-Pure Dealer.

III.C Filter Life

Filter life will vary in proportion to the amount of water used and the level of impurities in the water being processed. Claims of capacity are not applicable to contaminants reduced by mechanical filtration because of broad variations in the quality and quantity of physical matter in your drinking water. Your Multi-Pure filter will clog, protecting you from these contaminants, and your flow rate will diminish. See Section I.B - Operation and Maintenance Specifications for the capacity of your model.

It is recommended that filters be replaced annually or sooner if needed. For optimum performance and to maintain your warranty, it is essential that the filter be replaced when the first of the following occurs: (a) annually; (b) when the unit's rated capacity is reached; (c) the flow rate diminishes; (d) the filter becomes saturated with bad tastes and odors.

IV. Below the Sink Installations

IV.A Required Tool List

The following tools are required to install your below sink Multi-Pure Drinking Water System:

Installation of Faucet/Spigot (Ceramic/Porcelain Sink):

- 3/8" Reversible Electric Drill
- 7/16" high speed steel drill bit
- 1/2" carbide tipped masonry drill bit
- Hammer
- Center punch
- 8" adjustable wrench
- Pliers or Vise Grips

Installation of Faucet/Spigot (Stainless Steel Sink):

- all of the above (except masonry drill bit), plus.....
- 1/8" high speed drill bit

Adapta Valve Installation:

- 8" adjustable wrench
- Wire Cutter or Knife

Installation of Capacity Monitor:

- (see tool list in Section V.C)

Drinking Water Systems designed for use below the sink and can easily be installed on the incoming cold water line. The unit is connected to a specially designed stainless steel faucet (spigot) which installs directly on your sink, requiring little space. Your Below Sink Unit is shipped with only one installation kit. Alternate accessories may be purchased at a minimal cost.

You can refer to the below sink drawings on page 4 and 9.



Model CB-As-SB

IV.B. Attaching the Adapters to the Housing

Below Sink models are shipped with the adapters / connectors appropriate for your Multi-Pure Drinking Water System. The following shows the connectors / adapters that would be included with your unit. Now is the time to attach the connectors to the housing top.

Stainless Steel Housing

To connect straight adapters:

1. Connect the 1/4" connector to the OUTLET opening on the housing by turning clockwise. Tighten by hand and then give one to two more turns with a wrench.
2. Connect the 1/4" INLET adapter / connector to the INLET opening on the unit housing by turning clockwise. Tighten by hand and then give one to two extra turns with a wrench.

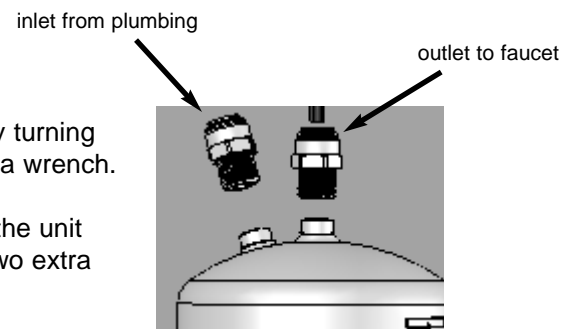

IV.C Housing Assembly

Housing Assembly

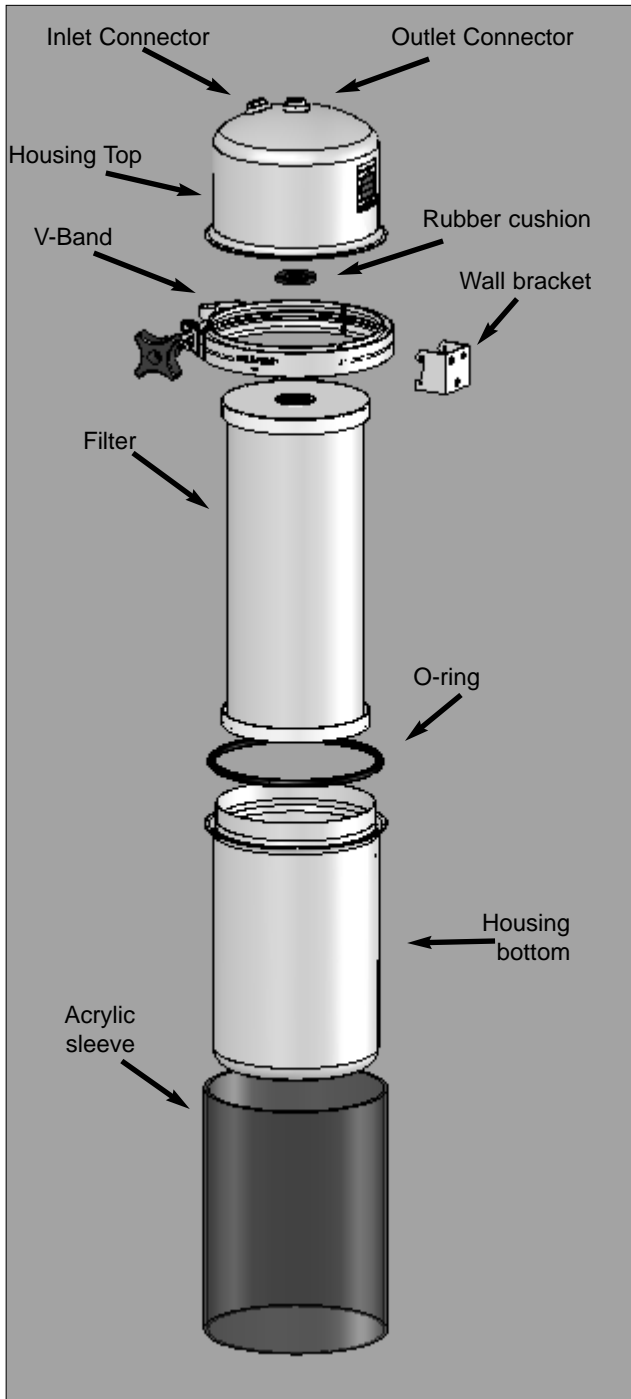

Below Sink Installation Includes:



Stainless Steel Faucet with blue tubing attached



1/4" Inlet Connector



1/4" Outlet Connector

Adapta Valve Assembly

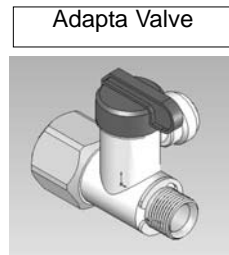

Adapta Valve



Threading Adapter

Capacity Monitor Options

For CB-VOC-SB-PID



Filter Monitor Box

Capacity Flow Device



Black track washer (under faucet)



For CB-As-SB-PID

Filter Monitor Box and Capacity Flow Device



V. Installing the Faucet

Now that you have the housing ready, proceed with the faucet installation. The following instructions are for installing at your sink the special drinking water faucet included with your below sink model. Determine the type of faucet included with your unit and review the instructions for installing your type of faucet.

Faucet: For instructions on installing the faucet with tubing attached, see Section V.B.

Faucet with Capacity Monitor: For instructions on installing the the faucet and Capacity Monitor, see Section V.C.



V.A Drilling the Hole

1. Porcelain or Ceramic Sink

1. Select and mark the spot for mounting the faucet on your sink top.
 - a. Confirm that there are no reinforcing ribs under the sink location you select for your faucet.
 - b. If you have an extra hole in your sink for a rinsing hose, you may want to disconnect that hose and use the existing hole for your drinking water faucet.
2. Using the hammer and center punch, make an indentation by tapping the center punch gently on the ceramic/porcelain where the hole is to be drilled.
3. Use the ½" carbide tipped masonry drill bit to grind away the porcelain down to the metal, clearing away enough porcelain to allow for drilling a hole without damaging the porcelain surface.
4. Carefully use the 7/16" high speed steel drill bit (CAUTION: do not allow the 7/16" bit to "grab" the porcelain - this would damage the porcelain surface) to completely drill a hole through the metal sink.

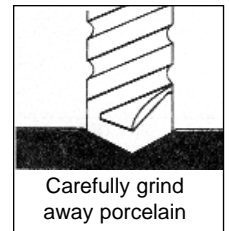
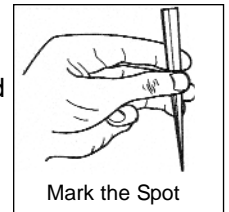

2. Stainless Steel or Metal Sink

You will need to use a 1/8" high speed drill bit in addition to the other tools listed for the installation of a faucet on a stainless steel sink.

1. Select and mark the spot for mounting the faucet in your sink. If you have an extra hole for a rinsing hose at your sink, you may want to disconnect that hose and use the existing hole for your drinking water faucet.
2. Using the hammer and center punch, make an indentation where the hole is to be drilled.
3. Use the 1/8" high speed steel drill bit to drill a pilot hole.
4. Use the 7/16" high speed steel drill bit to completely drill a hole through the stainless steel sink.

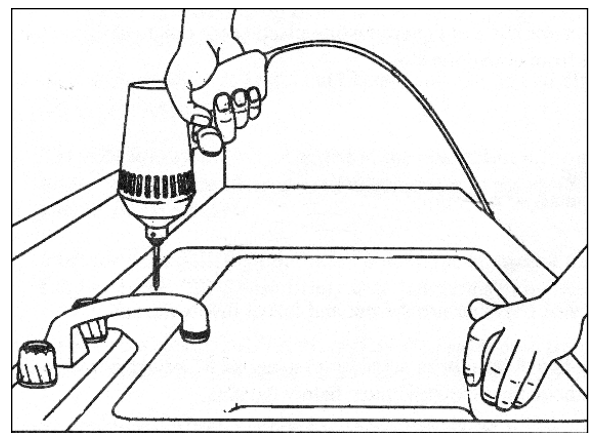

V.B Installing the Faucet



Complete Faucet Assembly
with Blue Tubing

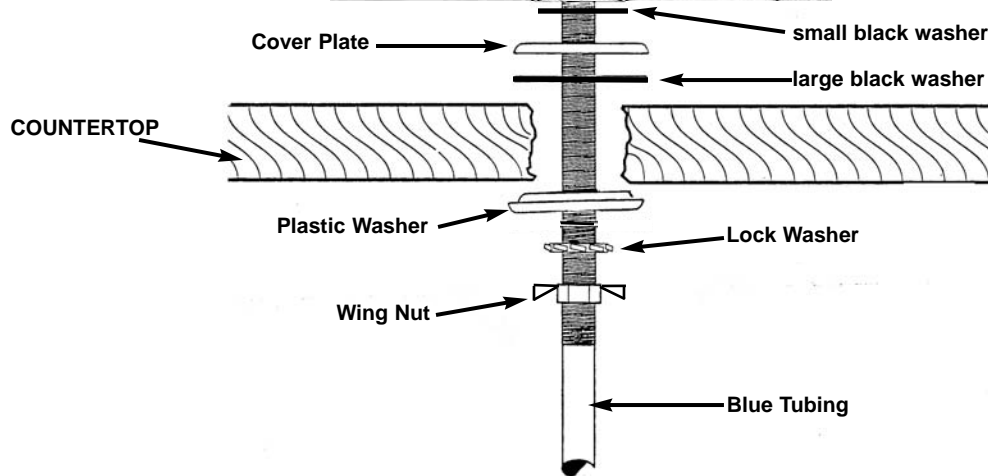

Mounting the Faucet

1. Note that the blue tubing is attached to the faucet.
2. **From the sink / counter top**, place over the faucet hole:
 - a. The larger soft black rubber washer
 - b. The cover plate
 - c. The smaller soft black rubber washer
3. **From under the sink**, slide over the blue tubing:
 - a. the black plastic (hard) washer (with the small side up)
 - b. lock washer
 - c. the wing nut
4. Hand tighten the wing nut to secure the faucet. Using vice grips, secure the wing nut and faucet below the sink.
5. From above the sink, (CAUTION: protect the faucet base from scratching) using an 8" adjustable wrench, turn the faucet base clockwise until firm. Then remove the vise grips from below the sink.



To operate your Multi-Pure Faucet, just turn the handle on for continuous flow. To stop flow, return the handle to its original position.

The faucet is now ready to be connected to your drinking water unit.

V.C Installing the Faucet with a Capacity Monitor

Model Nos. CB-As-SB-PID and CB-VOC-SB-PID are equipped with a Capacity Monitor that flashes red when the filter should be changed. Models with capacity monitors are equipped with a chrome-plated designer faucet with the tubing attached. In addition you will receive the Capacity Monitor (consists of two pieces), two adapters, and additional tubing (see diagram and parts list below). Not included but required for installation are two AA batteries.

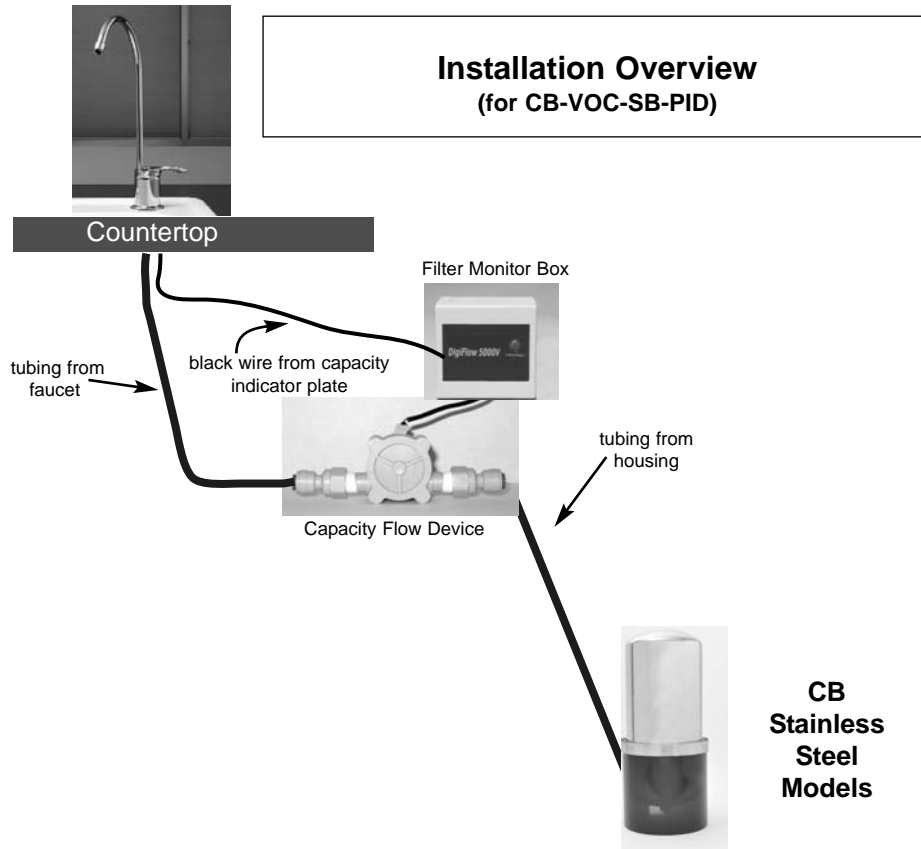

Faucets with Capacity Monitor include:

- 1 spout
- 2 faucet handle
- 3 faucet base
- 4 faucet stud
- 5 tubing (blue) attached to faucet
- 6 smaller rubber washer
- 7 capacity indicator plate (black)
- 8 black wire (attached to #7)
- 9 larger rubber washer
- 10 hard black washer with side cut
- 11 track washer
- 12 lock washer
- 13 wing nut
- 14 capacity flow device
- 15 filter monitor box
- 16 adapters (MC744), two
- 17 tubing from capacity flow device to housing outlet

Mounting the Faucet with a Capacity Monitor:

1. Follow the preceding instructions for drilling the hole; however, use the 1/2" drill bit all the way through the sink instead of the 7/16" drill bit to allow room to feed the faucet stud and the monitor cable down through the hole in the sink.
2. Note that the blue tubing is attached to the faucet.
3. **From the sink / counter top**, place over the faucet hole:
 - a. The larger soft black rubber washer (#9).
 - b. Then the Capacity Indicator Plate (#7); feed the attached black cable (#8) through the hole in the sink / counter. Position the Capacity Indicator Plate so that the indicator light will be easy to see.
 - c. Place the smaller soft black rubber washer (#6) over the Capacity Indicator Plate.
 - d. Place the faucet base (#3) on the soft washer and Capacity Indicator Plate, feeding the faucet stud and blue tubing down through the hole in the sink / counter. The faucet stud will now be accessible from below the sink.
4. **From under the sink**, do the following:
 - a. Slide the black "track" washer (#11) over the threaded faucet stud with the flat side down. Guide the black wire (#8) through the "track" to assure that the wire will be protected in the track and not be pinched between the sink /counter and the stud nut.
 - b. Slide the black plastic hard washer (#10) (with the small side up) over the blue tubing (#5), black wire (#6) and faucet stud (#4).
 - c. Slide the lock washer (#12) on the faucet stud.
 - d. Screw on the stud wing nut (#13), hand-tightening it just enough to keep the faucet secure on the sink top.

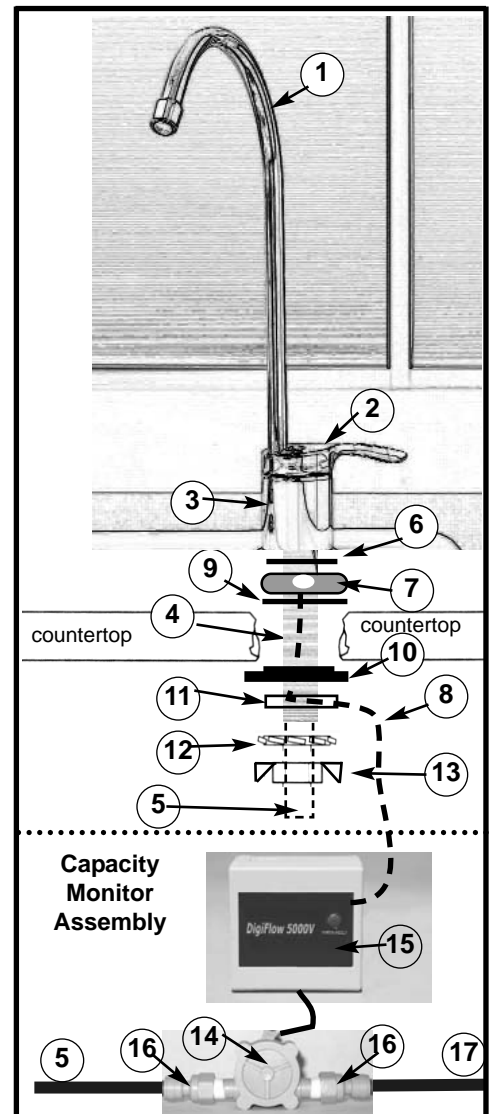

V.C Mounting the Faucet with a Capacity Monitor (continued):

Installation of the Capacity Monitor

1. Preparing the Filter Monitor Box (#15):

- Guide the black wire (# 7) from under the sink to the Filter Monitor Box (#15) and connect the two plugs.
- Open the Filter Monitor Box and pull out the battery holder. Then insert two AA batteries (not included), matching polarity shown on the battery holder. Press the check/reset button for six seconds. There will be a long audio sound, and the LED on the Capacity Indicator Plate will flash red and then green several times.
- Snap the cover back onto the Filter Monitor Box.
- Peel off the paper backing from the Velcro® and attach one piece to the back of the Filter Monitor Box. Select a clean, convenient location to mount the Box on your cabinet wall under the sink, allowing sufficient space for placement of the capacity flow device (#14) which is attached by a wire to the Filter Monitor Box. Press the second piece of Velcro® to the cabinet wall and press the Box onto the wall. .

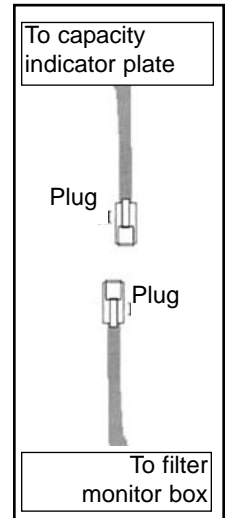

2. Preparing the Capacity Flow Device (#14):

- Attach the two adapters (#16) to the capacity flow device (#14) -- one on each side.
- Complete the installation after connecting the tubing (see next step).

Connecting the Tubing (See Section VII.B for tips on connecting tubing)

Faucet Connection:

Connect the blue tubing attached to the faucet to the adapter (#16) on the OUTLET (faucet) (#5) side of the Capacity Flow Device (see the arrow on the Device for the direction of the water flow.)

- Using wire cutters or knife, cut (square cut) the tip end off of the blue plastic tube connected to the faucet. Do not use scissors.
- The tubing must be fully inserted in the adapter. It is recommended that you measure and mark the end of the tubing that you are inserting in the adapter to assure that it is inserted as far as it will go. The 1/4" blue tubing should be inserted about 5/8".

Insert blue tubing 5/8"

- Push the tubing through the small hole in the adapter until you feel resistance; at this point, the tubing is not fully inserted. Then push firmly until the tubing is inserted as far as it will go (see Item 2 above for measurement).

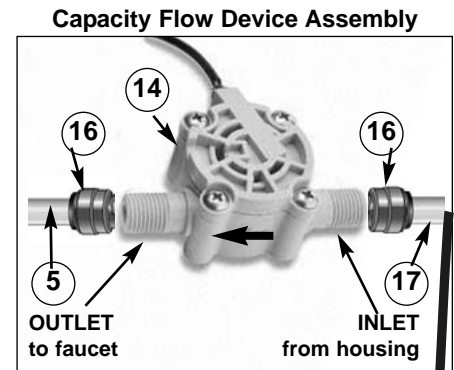

Pull to check that the tubing is secure.

Insert tubing and push until you feel resistance -- at this point, the tubing is not fully inserted. Push firmly until the tubing is inserted as far as it will go.

Housing Connection:

NOTE: A separate piece of blue tubing is included with your shipment. Attach this separate piece of tubing between the housing OUTLET port and the Capacity Flow Device INLET port. Read this section first and then complete the installation of your drinking water system (See Section V.II).

When you have completed the installation of your drinking water system below your sink, then connect the separate piece of blue tubing (#17) to the small straight adapter that you previously attached to the OUTLET port of the housing and then to the adapter on the INLET side of the Capacity Flow Device.

- Using wire cutters or knife, cut (square cut) the tips off of both ends of the plastic tube to be connected between the housing OUTLET port and the Capacity Flow Device INLET port. Do not use scissors.
- The tubing must be fully inserted in the adapters. It is recommended that you measure and mark the end of the tubing that you are inserting in the adapter to assure that it is inserted as far as it will go. The 1/4" tubing should be inserted about 5/8".
- Push the tubing through the small hole in the adapters until you feel resistance; at this point, the tubing is not fully inserted. Then push firmly until the tubing is inserted as far as it will go (see Item 2 above for measurement).

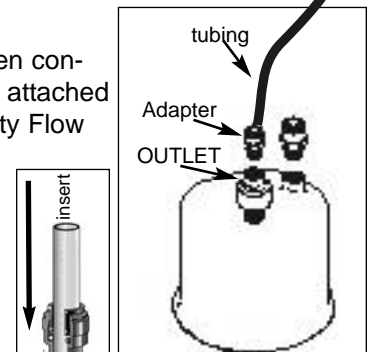

V.C Mounting the Faucet with a Capacity Monitor (continued):

Operation and Maintenance of Models with Capacity Monitor:

Multi-Pure Drinking Water Systems that are equipped with a capacity monitor let you know when the filter should be changed. When you turn on your Multi-Pure drinking water faucet, and water flows through the capacity monitor, the **green light** on the capacity indicator plate flashes several times to let you know that the System has not reached its certified capacity. The number of green flashes will decrease as the capacity of your monitor is used. When it flashes just two times, only 20% of your capacity remains; one time indicates only 10% of the capacity remains. It is recommended that you order a replacement filter when you reach the 20% capacity level.

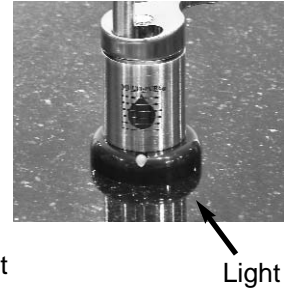

A **red light** will flash alerting you that the capacity of your filter has been fully used and that you should immediately replace the filter. You also will hear an audio alert (buzzer).

As with all drinking water treatment devices which reduce certain contaminants by mechanical filtration, the capacity of the filter will vary and is dependent upon type and level of contaminants in your water. It is recommended that a prefilter be installed in front of models with a capacity monitor when used on water with high levels of particulate matter.

It is recommended that you replace the filter cartridge when the first of the following occurs: a) annually; b) the red light flashes on the capacity indicator plate, indicating that the unit's rated capacity has been reached; c) the flow rate diminishes; or d) the filter becomes saturated with bad tastes and odors.

Capacity of models with a Performance Indicator Device is:
1200 gallons for CB-VOC-PID Model
960 gallons for CB-As-SB-PID Model

VI. CONNECTING TO YOUR PLUMBING - Adapta Valve Installation

The Adapta Valve assembly (MC930ASBL) includes:

- Adapta Valve (with shut-off valve attached)
- Tubing Adapter

Adapta Valve

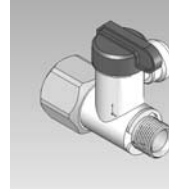

Adapter

NOTE: When attaching the Adapta Valve to straight pipe threads, use Teflon tape on the threads. Wrap the tape around the pipe only once.

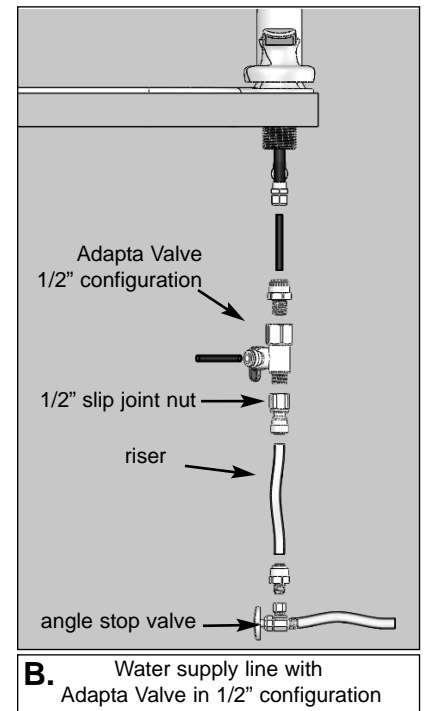
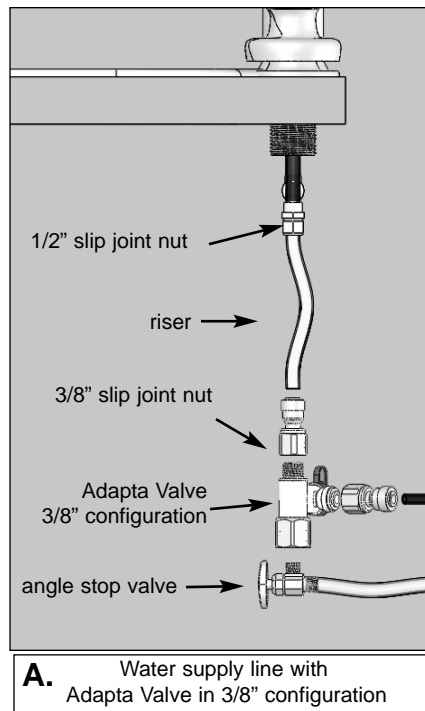
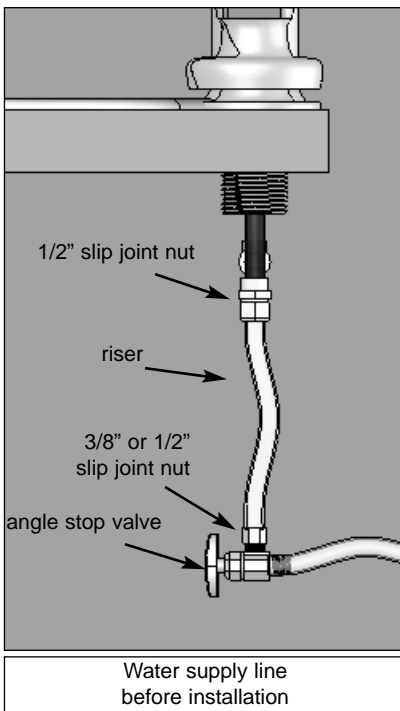

VI. Connecting to Your Plumbing (continued)

Choose the configuration (3/8" or 1/2") that fits your plumbing. The 3/8" configuration usually is installed at the bottom of the riser at the angle stop valve. The 1/2" configuration can be installed at the top of the riser at the faucet pipe or at the bottom of the riser at the angle stop valve.

A. Use the 3/8" configuration on a water supply line with a 3/8" slip joint.

B. Install with the 1/2" configuration at the top of the riser on a water supply line that does not have a slip joint nut at the angle stop valve. If there is a 1/2" slip joint nut at the angle stop valve, the adapta valve in the 1/2" configuration can be installed at the angle stop valve.



3/8"
configuration



1/2"
configuration

Install on the cold water line only:

1. Turn off the cold water supply to the faucet by turning the angle stop valve completely off. You should have on hand a container to catch any residual water in the pipes.
2. Disconnect the cold water riser/supply line at the angle stop valve (or at your cold water faucet pipe, depending on the plumbing in your home) by turning the slip joint nut counter clockwise, using an 8" adjustable wrench.
3. Using the 8" adjustable wrench, connect to the Adapta Valve to the pipe (angle stop valve or your cold water faucet pipe) from which you removed the slip joint nut. Be sure the rubber washer is in place in the Adapta Valve. Turn clockwise until tight; however, DO NOT OVERTIGHTEN.
4. Connect the plumbing riser/supply line with the slip joint nut to the Adapta Valve. Be sure the supply line does not block the shut-off valve on the side of the Adapta Valve. If necessary, trim the supply line before reconnecting. Turn clockwise until tight.

5. Connect the clear 1/4" clear plastic tubing, shipped with the unit, to the Adapta Valve by inserting the tubing, as far as it will go, through the small hole in the Tubing adapter that you attached to the shut-off valve.

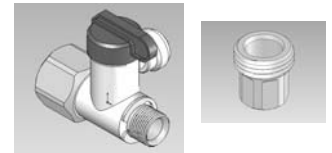

a. Cut (square cut) the tip ends off the tubing using a sharp knife. Do not use scissors.

b. The tubing must be fully inserted in the opening of the shut-off valve. It is recommended that you measure and mark the end of the tubing. The 1/4" clear tubing should be inserted about 5/8".

Insert clear tubing 5/8"

c. Push the tubing through the small hole in the valve until you feel resistance -- at this point, the tubing is not fully inserted. Then push firmly until the tubing is inserted as far as it will go.

Push the tubing into the small hole as far as it will go. Pull to check secure.

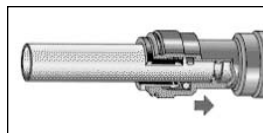

6. Confirm that the Unit Shut-off Valve (attached to the Adapta Valve) is in the OFF position by turning the handle clockwise until it stops.

7. To connect the tubing to your drinking water unit proceed to Section VII.

VII. CONNECTING THE DRINKING WATER SYSTEMS

Now that you have installed the filter, adapters, and faucet and connected to the plumbing you are ready to complete the installation of your Drinking Water System.

Reference Section II.A for installing the filter and Section IV.B for housing adapters.

Reference Section V for installing the faucet.

Reference Section VI for connecting to the plumbing.

VII.A Adapter Connection:

If you have not already installed the adapters, please refer to Section IV.B on page 8.

VII.B Tubing Connection:

Be sure to provide sufficient tubing for conveniently changing the filter when it is time to replace it.

1. Using wire cutters or knife, cut (square cut) the tip ends off of both plastic tubes (the blue tube connected to the faucet and the clear tube which you previously connected to the plumbing). Do not use scissors.
2. Insert the clear 1/4" tubing from the plumbing into the small hole in the INLET connector as far as it will go.
 - a. The tubing must be fully inserted in the valve or fitting; it is recommended that you measure and mark the end of the tubing that you are inserting in the fitting to assure that it is inserted as far as it will go. The 1/4" tubing should be inserted about 5/8". The 1/4" blue tubing should be inserted about 5/8".
 - b. Push the tubing through the small hole in the valve or fitting until you feel resistance, at this point, the tubing is not fully inserted. Then push firmly until the tubing is inserted as far as it will go (see Item a above for measurements).
 - c. Pull to check that the tubing is secure.

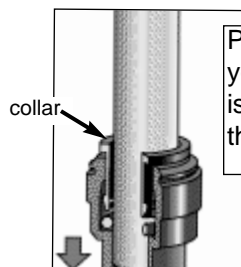
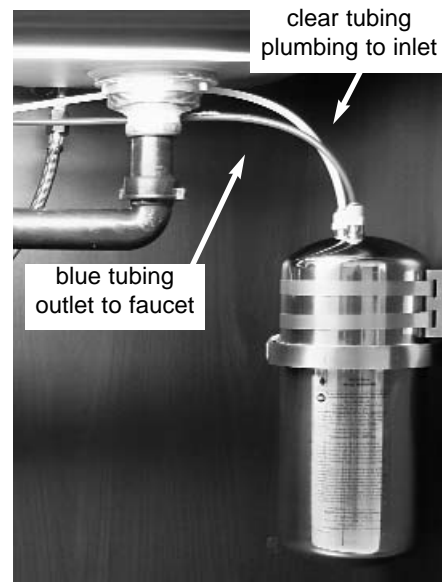

Push the tubing through the opening until you feel resistance, at this point, the tubing is not fully inserted. Then push firmly until the tubing is inserted as far as it will go.

Disconnecting the tubing: Should you need to disconnect the tubing for maintenance, first ensure that the system is depressurized. Push in the collar against the face of the fitting. With the collar held in this position the tubing can be removed.

VII. Connecting Your Drinking Water System (continued)

VII.C Ice-Maker Connection

In addition to using your Multi-Pure Drinking Water System to provide delicious, quality water at the sink, you may connect that same unit to your refrigerator to provide clean, clear water for your ice-maker. To connect to your refrigerator or a remote spigot, follow these steps.

Connecting to your unit:

1. Determine whether you have access to your refrigerator from your sink.
2. Cut 3" from the end of the blue faucet tubing,
3. Insert the tubing still connected to the faucet into the top of the icemaker tee. Push the tubing until you feel resistance - - at this point, the tubing is not fully inserted (see below -- Tubing Connections). Push firmly until it is inserted as far as it will go.
4. Insert one end of the loose blue tubing to the bottom port of the icemaker tee. Push the tubing until you feel resistance (see below -- Tubing Connections). Push firmly until the tubing is inserted as far as it will go.
5. Connect the other end of the blue tubing to the OUTLET connector that your previously installed on the housing of your unit.
6. Connect a separate 1/4" poly tube (available through your dealer or a plumbing supplier) to the side port of the tee. Provide sufficient tubing to reach your refrigerator and service unit and connect same to icemaker tee.

Connecting icemaker to stainless steel unit

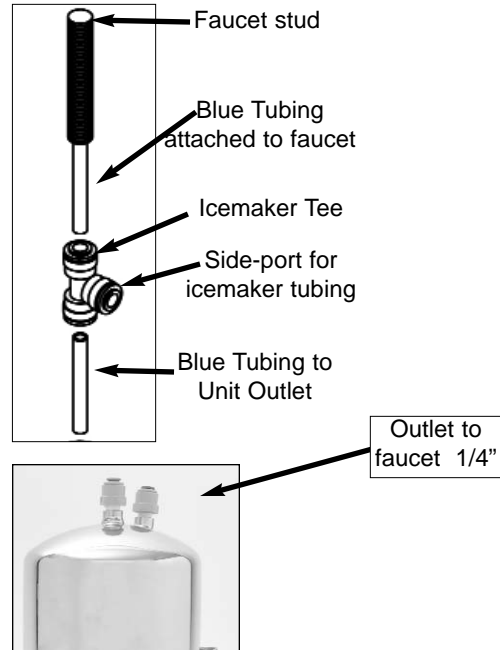

Tubing Connections:

Insert the tubing in the port of the tee / connector as far as it will go.

- a. The tubing must be fully inserted in the connector; it is recommended that you measure and mark the end of the tubing that you are inserting in the tee / connector to assure that it is inserted as far as it will go. The 1/4" blue tubing should be inserted about 5/8".
- b. Push the tubing through the small hole in the connector until you feel resistance, at this point, the tubing is not fully inserted. Then push firmly until the tubing is inserted as far as it will go (see Item above for measurements).
- c. Pull to check that the tubing is secure.

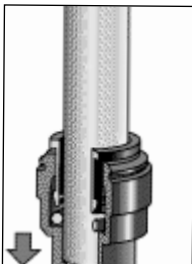

Push the tubing through the opening until you feel resistance, at this point, the tubing is not fully inserted. Then push firmly until the tubing is inserted as far as it will go.

VII.D Placing Your Unit Under Your Sink

Your Multi-Pure Drinking Water System will sit on the cabinet floor with acrylic base. Be sure to provide sufficient tubing for conveniently changing the filter when it is time to replace it. You may also mount the unit on the cabinet wall by purchasing an optional wall bracket from your dealer.



Model CB-As-SB

VII.E Installing Inline Models

Multi-Pure Inline models are ideal for refrigerators, water coolers, or restaurants where all water to a cold water outlet or faucet is filtered. Inline Models include the housing, filter, and adapters; no installation fixtures or accessories are provided. The inline models are appropriate for an in-line installation and can be used with your existing faucet. It is recommended that the inline models be installed by your dealer or a professional plumber in accordance with established plumbing procedures.



VIII. START-UP AND USE OF YOUR MULTI-PURE DRINKING WATER SYSTEM

Congratulations, your Drinking Water System has been connected to your plumbing and you are now ready to start-up the unit, as follows:

1. Using a paper towel or cloth, dry off all plumbing connections.
2. Also, dry off the drinking water unit.
3. Ensure that all connections are tight (CAUTION: DO NOT OVERTIGHTEN).
4. You are now ready to turn your water supply back on; turn on the Shut-Off Valve under your sink where water enters your residence.
5. Turn on the water going to your Drinking Water System by turning the handle on the Shut-Off Valve that you installed (see Section VI).
6. Open the drinking water faucet by turning the the operating lever (handle) to start the flow of water through the unit. You can adjust the flow rate of the faucet by turning the handle on the faucet.
7. Allow water to run through the unit and faucet for about 10 minutes so that all air can escape.
8. Adjust the handle on the Shut-off Valve so that the water flow to the drinking water faucet when it is fully open does not exceed 1.0 gpm (to measure flow rate - it takes approximately 15 seconds to fill a quart at 1.0 gallon per minute).
9. Close the drinking water faucet and check for leaks.
 - a. Check the V-Band to confirm that it is secured evenly around the housing top and bottom.
 - b. Hand-tighten the black knob on the V-Band until it is as tight as possible.
10. Allow water to run through the unit to waste for approximately 30 minutes to flush the filter of loose carbon fines.

Note: units with the capacity monitor please disconnect the monitor before flushing the filter. The carbon fines will clog the measuring device. Once you have flushed your filter, reconnect the monitor.

11. Shut off the water and check for leaks.

**Your Drinking Water System is now ready for use.
You can enjoy having great tasting, high quality water for drinking,
cooking, beverages, food preparation, etc. whenever you want it.**

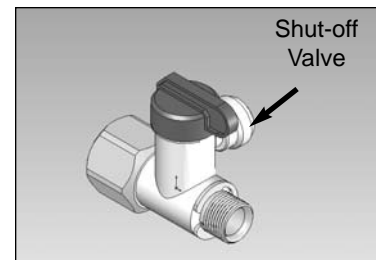

Filter Life

Filter life will vary in proportion to the amount of water used and the level of impurities in the water being processed. Claims of capacity are not applicable to contaminants reduced by mechanical filtration because of broad variations in the quality and quantity of physical matter in your drinking water. Your Multi-Pure filter will clog, protecting you from these contaminants, and your flow rate diminishes. See Section I.B - Operation and Maintenance Specifications for the capacity of your model.

It is recommended that filters be replaced annually or sooner if needed. For optimum performance and to maintain your warranty, it is essential that the filter be replaced when the first of the following occurs: (a) annually; (b) when the unit's rated capacity is reached; (c) the flow rate diminishes; (d) the filter becomes saturated with bad tastes and odors. When a capacity monitor is installed with its capacity-metered faucet, a red light flashes at the rated capacity, indicating when the filter should be changed. It is recommended that the filter be changed when the red light flashes, annually, or the flow rate diminishes.

IX. Performance Certification

Multi-Pure Drinking Water Systems Product Performance Tested and Certified

Multi-Pure Drinking Water Systems have been tested and certified by NSF International to comply with NSF/ANSI Standards for the reduction of specific contaminants being considered as established or potential health hazards.



Reduced by adsorption:

Arsenic V *
Chlorine, Aesthetic
Chloramine, Aesthetic
Chlordane
Lead
Mercury
MTBE
PCBs
Taste and Odors
Toxaphene
VOCs (listed below)

* CB-As-SB-PID and CB-VOC-SB-PID models reduce all contaminants shown. All other CB models reduce all contaminants except Arsenic V.

By mechanical filtration (filter life will vary):

Asbestos
Cyst (Giardia, Cryptosporidium, Entamoeba, Toxoplasma)
Particulate Matter, Nominal Particulate Reduction, Class I
Turbidity

Volatile Organic Chemicals (VOC) includes:

Disinfection By-Products

chloropicrin
haloacetonitriles (HAN):
bromochloroacetonitrile
dibromoacetonitrile
dichloroacetonitrile
trichloroacetonitrile
haloketones (HK):
1,1-dichloro-2-Propanone
1,1-trichloro-2-Propanone
trihalomethanes (THMs; TTHMs):
bromodichloromethane
bromoform
chloroform
dibromochloromethane
tribromoacetic acid

Pesticides

carbofuran
dibromochloropropane (DBCP)
o-dichlorobenzene
p-dichlorobenzene
endrin
ethylene dibromide (EDB)
heptachlor
heptachlor epoxide
lindane
methoxychlor

Herbicides

alachlor
atrazine
2,4-D
dinoseb
pentachlorophenol
2,4,5-TP (silvex)

Chemicals

benzene
carbon tetrachloride
chlorobenzene
1,2-dichloroethane
1,1-dichloroethylene
cis-1,2-dichloroethylene
1,2-dichloropropane
cis-1,3-dichloropropylene
ethylbenzene
hexachlorobutadiene
hexachlorocyclopentadiene
simazine
styrene
1,1,2,2-tetrachloroethane
tetrachloroethylene
toluene
trans-1,2-dichloroethylene
1,2,4-trichlorobenzene
1,1,1-trichloroethane
1,1,2-trichloroethane
trichloroethylene
xylenes (total)

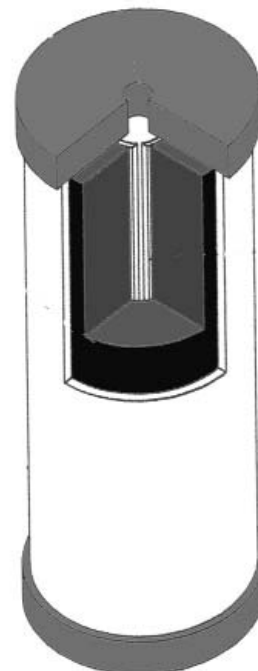

X. Performance Data Sheet



Performance Data Sheet

Multi-Pure Drinking Water Systems have been tested and certified under NSF/ANSI Standard No. 53 as shown below. The concentration of the indicated substances in water entering the system was reduced to a concentration less than or equal to the permissible limit for water leaving the system, as specified in NSF/ANSI 53 HEALTH EFFECTS



Model Nos. CB-VOC-SB, CB-VOC-SC, CB-VOC-SI, CB-VOC-PID

Substance	Percent Reduction**	Influent challenge concentration	Maximum permissible product water concentration
ALACHLOR*	>98%	0.05	0.001
ASBESTOS	>99.9%	10 ⁷ to 10 ⁸ fibers/L; fibers greater than 10 micrometers in length	99% reduction requirement
ATRAZINE*	>97%	0.1	0.003
BENZENE*	>99%	0.081	0.001
BROMODICHLOROMETHANE (TTHM)*	>99.8%	0.3	0.015
BROMOFORM (TTHM)*	>99.8%	0.3	0.015
CARBOFURAN (Furadan)*	>99%	0.19	0.001
CARBON TETRACHLORIDE*	98%	0.078	0.0018
CHLORDANE	>99.5%	0.04 +/-10%	0.002
CHLOROBENZENE (Monochlorobenzene)*	>99%	0.077	0.001
CHLOROPICRIN*	99%	0.015	0.0002
CHLOROFORM (TTHM)* (surrogate chemical)	>99.8%	0.45 +/- 20%	0.080
Cryptosporidium (CYST)	99.95%	minimum 50,000/mL	99.95%
CYST (Giardia; Cryptosporidium; Entamoeba; Toxoplasma)	99.95%	minimum 50,000/mL	99.95%
2, 4-D*	98%	0.110	0.0017
DBCP (see Dibromochloropropane)*	>99%	0.052	0.00002
1,2-DCA (see 1,2-DICHLOROETHANE)*	95%	0.088	0.0048
1,1-DCE (see 1,1-DICHLOROETHYLENE)*	>99%	0.083	0.001
DIBROMOCHLOROMETHANE (TTHM; Chlorodibromomethane)*	>99.8%	0.300	0.015
DIBROMOCHLOROPROPANE (DBCP)*	>99%	0.052	0.00002
o-DICHLOROBENZENE (1,2 Dichlorobenzene)*	>99%	0.08	0.001
p-DICHLOROBENZENE (para-Dichlorobenzene)*	>98%	0.04	0.001
1,2-DICHLOROETHANE (1,2-DCA)*	95%	0.088	0.0048
1,1-DICHLOROETHYLENE (1,1-DCE)*	>99%	0.083	0.001
CIS-1,2-DICHLOROETHYLENE*	>99%	0.17	0.0005
TRANS-1,2- DICHLOROETHYLENE*	>99%	0.086	0.001
1,2-DICHLOROPROPANE (Propylene Dichloride)*	>99%	0.08	0.001
CIS-1,3- DICHLOROPROPYLENE*	>99%	0.079	0.001
DINOSEB*	99%	0.17	0.0002
EDB (see ETHYLENE DIBROMIDE)*	>99%	0.044	0.00002
ENDRIN*	99%	0.053	0.00059
Entamoeba (see CYSTS)	99.95%	minimum 50,000/mL	99.95%
ETHYLBENZENE*	>99%	0.088	0.001
ETHYLENE DIBROMIDE (EDB)*	>99%	0.044	0.00002
Furadan (see CARBOFURAN)*	>99%	0.19	0.001
Giardia Lamblia (see CYST)	>99.95%	minimum 50,000/mL	99.95%

** Percent reduction reflects actual performance of Multi-Pure product as specifically tested (at 200% of capacity). Percent reduction shown for VOCs* reflects the allowable claims for Volatile Organic Chemicals/Compounds as per Tables. Chloroform was used as a surrogate for VOC reduction claims; the Multi-Pure Systems actual reduction rate of Chloroform was >99.8% as tested (at 200% capacity).

Substance	Percent Reduction**	Influent challenge concentration	Maximum permissible product water concentration
HALOACETONITRILES (HAN)*			
BROMOCHLOROACETONITRILE	98%	0.022	0.0005
DIBROMOACETONITRILE	98%	0.024	0.0006
DICHLOROACETONITRILE	98%	0.0096	0.0002
TRICHLOROACETONITRILE	98%	0.015	0.0003
HALOKETONES (HK):			
1,1-DICHLORO-2-PROPANONE	99%	0.0072	0.0001
1,1,1-TRICHLORO-2-PROPANONE	96%	0.0082	0.0003
HEPTACHLOR*	>99%	0.08	0.0004
HEPTACHLOR EPOXIDE*	98%	0.0107	0.0002
HEXACHLOROBUTADIENE (Perchlorobutadiene)*	>98%	0.044	0.001
HEXACHLOROCYCLOPENTADIENE*	>99%	0.060	0.000002
LEAD (pH 6.5)	>99.3%	0.15 +/- 10%	0.010
LEAD (pH 8.5)	>99.3%	0.15 +/- 10%	0.010
LINDANE*	>99%	0.055	0.00001
MERCURY (pH 6.5)	>99%	0.006 +/- 10%	0.002
MERCURY (pH 8.5)	>99%	0.006 +/- 10%	0.002
METHOXYCHLOR*	>99%	0.050	0.0001
Methylbenzene (see TOLUENE)*	>99%	0.078	0.001
Monochlorobenzene (see CHLOROBENZENE)*	>99%	0.077	0.001
MTBE (methyl tert-butyl ether)	>96.6%	0.015 +/- 20%	0.005
POLYCHLORINATED BIPHENYLS (PCBs , Aroclor 1260)	>99.9%	0.01 +/- 10%	0.0005
PCE (see TETRACHLOROETHYLENE)*	>99%	0.081	0.001
PENTACHLOROPHENOL*	>99%	0.096	0.001
Perchlorobutadiene (see HEXACHLOROBUTADIENE)*	>98%	0.044	0.001
Propylene Dichloride (see 1,2 -DICHLOROPROPANE)*	>99%	0.080	0.001
SIMAZINE*	>97%	0.120	0.004
Silvex (see 2,4,5-TP)*	99%	0.270	0.0016
STYRENE (Vinylbenzene)*	>99%	0.15	0.0005
1,1,1-TCA (see 1,1,1 - TRICHLOROETHANE)*	95%	0.084	0.0046
TCE (see TRICHLOROETHYLENE)*	>99%	0.180	0.0010
1,1,2,2- TETRACHLOROETHANE*	>99%	0.081	0.001
TETRACHLOROETHYLENE*	>99%	0.081	0.001
TOLUENE (Methylbenzene)*	>99%	0.078	0.001
TOXAPHENE	>92.9%	0.015 +/- 10%	0.003
Toxoplasma (see CYSTS)	99.95%	minimum 50,000/ml	99.95%
2,4,5-TP (Silvex)*	99%	0.270	0.0016
TRIBROMOACETIC ACID*		0.042	0.001
1,2,4 TRICHLOROENZENE (Unsymtrichlorobenzene)*	>99%	0.160	0.0005
1,1,1-TRICHLOROETHANE (1,1,1-TCA)*	95%	0.084	0.0046
1,1,2-TRICHLOROETHANE*	>99%	0.150	0.0005
TRICHLOROETHYLENE (TCE)*	>99%	0.180	0.0010
TRIHALOMETHANES (TTHM) (Chloroform; Bromoform; Bromodichloromethane; Dibromochloromethane)	>99.8%	0.45 +/- 20%	0.080
TURBIDITY	>99%	11 +/- NTU	0.5 NTU
Unsym-Trichlorobenzene (see 1,2,4-	>99%	0.160	0.0005
Vinylbenzene (see STYRENE)*	>99%	0.150	0.0005
XYLENES (TOTAL)*	>99%	0.070	0.001

Note: This addresses the U.S. Environmental Protection Agency (USEPA) Primary and Secondary Drinking Water Regulations in effect at its time of publication, as they related to Multi-Pure's performance in conformance to the industry performance criteria. These regulations are continually being updated at the Federal level. Accordingly, this list of MCLs will be reviewed and amended when appropriate.

NSF/ANSI 42 - AESTHETIC EFFECTS

The systems have been tested according to NSF/ANSI Standard No. 42 for the reduction of the following substances. The concentration of the indicated substances in water entering the system was reduced to a concentration less than or equal

Substance	Percent Reduction**	Influent challenge concentration	Maximum permissible product water concentration
CHLORAMINE as Aesthetic Effect (As Monochloramine)	>97%	3.0 mg/L +/- 10%	0.5 mg/L
CHLORINE as Aesthetic Effect	99%	2.0 Mg/L +/- 10%	> or = 75%*
PARTICULATE , (Nominal Particulate Reduction, Class I, Particles 0.5 TO <1 UM)	Class I > 99%	At Least 10,000 particles/mL	> or = 85%*

FOOTNOTES:

1. Multi-Pure Drinking Water Systems have been certified, as indicated, by NSF International for compliance to NSF/ANSI Standard Nos. 42 and 53.
2. The Multi-Pure Drinking Water Systems have been certified by the State of California Department of Public Health for the reduction of specific contaminants listed herein.
3. Chloroform was used as a surrogate for claims of reduction of VOCs. Multi-Pure Systems tested at >99.8% actual reduction of Chloroform. Percent reduction shown herein reflects the allowable claims for VOCs as per tables in the Standard.
4. **Do not use with water that is microbiologically unsafe or with water of unknown quality without adequate disinfection before or after the unit. Systems certified for cyst reduction may be used on disinfected waters that may contain filterable cysts.**
5. Filter life will vary in proportion to the amount of water used and the level of impurities in the water being processed. For optimum performance and to maintain your warranty, it is essential that the filter be replaced when the first of the following occurs: (a) annually; (b) when the unit's rated capacity is reached; (c) the flow rate diminishes; (d) the filter becomes saturated with bad tastes and odors.
6. Model No. CB-VOC-PID includes a capacity monitor that automatically flashes a yellow light when it is time to replace your filter.
7. Multi-Pure Drinking Water System housings are warranted for a lifetime; all exterior hoses and attachments to the System are warranted for one year. Please see the Owner's Manual for complete product guarantee and warranty information.
8. Please see the Owner's Manual for installation instructions and operating procedures.
9. In compliance with New York law, it is recommended that before purchasing a water treatment system, NY residents have their water supply tested to determine their actual water treatment needs. Please compare the capabilities of the Multi-Pure unit with your actual water treatment needs.
10. While testing was performed under standard laboratory conditions, actual performance may vary.
11. The list of substances which the treatment device reduces does not necessarily mean that these substances are present in your tap water.

Operational Specifications

CB-VOC-Sx series	
Replacement Filter Type	CBTVOC
Approximate Filter Capacity	750 gallons/1200 gallons*
Approximate Flow Rate @ 60 psi	.75 gpm
Maximum Working Pressure	100 psi/ 8.8 kg/cm ²
Minimum Working Pressure	30 psi/ 2.1 kg/cm ²
Maximum Operating Temperature	100°F/38°C for cold water use only
Minimum Operating Temperature	32°F/0°C for cold water use only
* with end-of-life indicator (PID)	



CB-VOC-SC

California Department of Public Health Certification / Registration

State of California
Department of Health Services
Water Treatment Device
Certificate Number
03 - 1580
Date Issued: June 25, 2003
Date Revised: February 9, 2004

Trademark/Model Designation	Replacement Element(s)
Multi-Pure Plus CB-SB	MPPTCB
Multi-Pure Plus CB-SC	MPPTCB
Multi-Pure Plus CB-SI	MPPTCB
Multi-Pure CB-VOC-SB	CBTVOC
Multi-Pure CB-VOC-SC	CBTVOC
Multi-Pure CB-VOC-SI	CBTVOC
Manufacturer: Multi-Pure	

The water treatment device(s) listed on this certificate have met the testing requirements pursuant to Section 116830 of the Health and Safety Code for the following health related contaminants:

Microbiological Contaminants and Turbidity:

Cysts
Turbidity

Inorganic/Radiological Contaminants:

Asbestos
Lead
Mercury

Organic Contaminants:

Chloroform
MTBE
PCE
Toxaphene
VOCs

Alachlor
Atrazine
Benzene
Carbofuran
Carbon Tetrachloride
Chlorobenzene
Chloroform
2,4-D
DBCP
o-Dichlorobenzene
p-Dichlorobenzene
1,2-Dichloroethane
1,1-Dichloroethylene
cis-1,2-Dichloroethylene
trans-1,2-Dichloroethylene
1,2-Dichloropropane
cis-1,3-Dichloropropylene
Dioxin

Endrin
Ethylbenzene
EDB
Halocarboniles (HAM)
Hexachlorocyclopentadiene
Dibromocyclopentadiene
Dichlorocyclopentadiene
Trichlorocyclopentadiene
Haloketones (HK)
1,1-Dichloro-2-Propanone
1,1,1-Trichloro-2-Propanone
Heptachlor
Heptachlor Epoxide
Hexachlorocyclopentadiene
Hexachlorocyclopentadiene
Lindane
Methoxychlor
Pentachlorophenol

Simazine
Styrene
1,1,2,2-Tetrachloroethane
Tetrachloroethylene
Toluene
2,4,5-TP (Silvex)
Trichloroacetic Acid
1,2,4-Trichlorobenzene
1,1,1-Trichloroethane
1,1,2-Trichloroethane
Trichloroethylene
Trihalomethanes: (THM's)
Bromodichloromethane
Bromoform
Chloroform
Chlorodibromomethane
Xylene

Rated Service Capacity: 750 gal

Rated Service Flow: 0.75 gpm

Do not use where water is microbiologically unsafe or with water of unknown quality, except that systems certified for cyst reduction may be used on disinfected water that may contain filterable cysts.

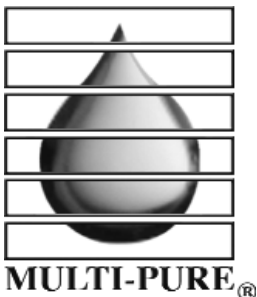

**Multi-Pure
Drinking Water Systems**

7251 Cathedral Rock Dr.
Las Vegas, NV 89128
866-622-9373
BR170CB-1006
www.multipureplus.com
info@multipureplus.com

X. Performance Data Sheet (continued)

Performance Data Sheet

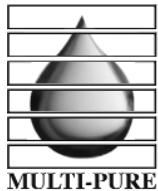

Multi-Pure Drinking Water Systems have been tested and certified under NSF/ANSI Standard No. 53 as shown below. The concentration of the indicated substances in water entering the system was reduced to a concentration less than or equal to the permissible limit for water leaving the system, as specified in **NSF/ANSI 53 HEALTH EFFECTS**



For Model Nos: CB-As-SB; CB-As-SC; CB-As-SI; CB-As-SB-PID;

Substance	Percent Reduction**	Influent challenge concentration	Maximum permissible product water concentration
ALACHLOR*	>98%	0.05	0.001
ARSENIC (pentavalent As (V); As (+5); arsenate @ 6.5 pH)	>99.9%	0.050 +/- 10%	0.010
ARSENIC (pentavalent As (V); As (+5); arsenate @ 8.5 pH)	>95.8%	0.050 +/- 10%	0.010
ASBESTOS	>99.9%	10 ⁷ to 10 ⁸ fibers/L; fibers greater than 10 micrometers in length	99% reduction requirement
ATRAZINE*	>97%	0.1	0.003
BENZENE*	>99%	0.081	0.001
BROMODICHLOROMETHANE (TTHM)*	>99.8%	0.3	0.015
BROMOFORM (TTHM)*	>99.8%	0.3	0.015
CARBOFURAN (Furadan)*	>99%	0.19	0.001
CARBON TETRACHLORIDE*	98%	0.078	0.0018
CHLORDANE	>99.5%	0.04 +/-10%	0.002
CHLOROBENZENE (Monochlorobenzene)*	>99%	0.077	0.001
CHLOROPICRIN*	99%	0.015	0.0002
CHLOROFORM (TTHM)* (surrogate chemical)	>99.8%	0.45 +/- 20%	0.080
Cryptosporidium (CYST)	>99.99%	minimum 50,000/L	99.95%
CYST (Giardia; Cryptosporidium; Entamoeba; Toxoplasma)	>99.99%	minimum 50,000/L	99.95%
2, 4-D*	98%	0.11	0.00017
DBCP (see Dibromochloropropane)*	>99%	0.052	0.00002
1,2-DCA (see 1,2-DICHLOROETHANE)*	95%	0.088	0.0048
1,1-DCE (see 1,1-DICHLOROETHYLENE)*	>99%	0.083	0.001
DIBROMOCHLOROMETHANE (TTHM; Chlorodibromomethane)*	>99.8%	0.300	0.015
DIBROMOCHLOROPROPANE (DBCP)*	>99%	0.052	0.00002
o-DICHLOROBENZENE (1,2 Dichlorobenzene)*	>99%	0.08	0.001
p-DICHLOROBENZENE (para-Dichlorobenzene)*	>98%	0.04	0.001
1,2-DICHLOROETHANE (1,2-DCA)*	95%	0.088	0.0048
1,1-DICHLOROETHYLENE (1,1-DCE)*	>99%	0.083	0.001
CIS-1,2-DICHLOROETHYLENE*	>99%	0.17	0.0005
TRANS-1,2- DICHLOROETHYLENE*	>99%	0.086	0.001
1,2-DICHLOROPROPANE (Propylene Dichloride)*	>99%	0.08	0.001
CIS-1,3- DICHLOROPROPYLENE*	>99%	0.079	0.001
DINOSEB*	99%	0.17	0.0002
EDB (see ETHYLENE DIBROMIDE)*	>99%	0.044	0.00002
ENDRIN*	99%	0.053	0.00059
Entamoeba (see CYSTS)	99.99%	minimum 50,000/L	99.95%
ETHYLBENZENE*	>99%	0.088	0.001
ETHYLENE DIBROMIDE (EDB)*	>99%	0.044	0.00002
Furadan (see CARBOFURAN)*	>99%	0.19	0.001
Giardia Lamblia (see CYST)	>99.99%	minimum 50,000/L	99.95%

** Percent reduction reflects actual performance of Multi-Pure product as specifically tested (at 200% of capacity). Percent reduction shown for VOCs* reflects the allowable claims for Volatile Organic Chemicals/Compounds as per Tables. Chloroform was used as a surrogate for VOC reduction claims; the Multi-Pure Systems actual reduction rate of Chloroform was >99.8% as tested (at 200% capacity).

Substance	Percent Reduction**	Influent challenge concentration	Maximum permissible product water concentration
HALOACETONITRILES (HAN)*			
BROMOCHLOROACETONITRILE	98%	0.022	0.0005
DIBROMOACETONITRILE	98%	0.024	0.0006
DICHLOROACETONITRILE	98%	0.0096	0.0002
TRICHLOROACETONITRILE	98%	0.015	0.0003
HALOKETONES (HK):*			
1,1-DICHLORO-2-PROPANONE	99%	0.0072	0.0001
1,1,1-TRICHLORO-2-PROPANONE	96%	0.0082	0.0003
HEPTACHLOR*	>99%	0.08	0.0004
HEPTACHLOR EPOXIDE*	98%	0.0107	0.0002
HEXACHLOROBTADIENE (Perchlorobutadiene)*	>98%	0.044	0.001
HEXACHLOROCYCLOPENTADIENE*	>99%	0.060	0.000002
LEAD (pH 6.5)	>99.99%	0.15 +/- 10%	0.010
LEAD (pH 8.5)	>99.99%	0.15 +/- 10%	0.010
LINDANE*	>99%	0.055	0.00001
MERCURY (pH 6.5)	>99.99%	0.006 +/- 10%	0.002
MERCURY (pH 8.5)	>99.99%	0.006 +/- 10%	0.002
METHOXYCHLOR*	>99%	0.050	0.0001
Methylbenzene (see TOLUENE)*	>99%	0.078	0.001
Monochlorobenzene (see CHLOROBTADIENE)*	>99%	0.077	0.001
MTBE (methyl tert-butyl ether)	>96.6%	0.015 +/- 20%	0.005
POLYCHLORINATED BIPHENYLS (PCBs , Aroclor 1260)	>97%	0.01 +/- 10%	0.0005
PCE (see TETRACHLOROETHYLENE)*	>99%	0.081	0.001
PENTACHLOROPHENOL*	>99%	0.096	0.001
Perchlorobutadiene (see HEXACHLOROBTADIENE)*	>98%	0.044	0.001
Propylene Dichloride (see 1,2 -DICHLOROPROPANE)*	>99%	0.080	0.001
SIMAZINE*	>97%	0.120	0.004
Silvex (see 2,4,5-TP)*	99%	0.270	0.0016
STYRENE (Vinylbenzene)*	>99%	0.15	0.0005
1,1,1-TCA (see 1,1,1 - TRICHLOROETHANE)*	95%	0.084	0.0046
TCE (see TRICHLOROETHYLENE)*	>99%	0.180	0.0010
1,1,2,2- TETRACHLOROETHANE*	>99%	0.081	0.001
TETRACHLOROETHYLENE*	>99%	0.081	0.001
TOLUENE (Methylbenzene)*	>99%	0.078	0.001
TOXAPHENE	>92.9%	0.015 +/- 10%	0.003
Toxoplasma (see CYSTS)	99.99%	minimum 50,000/L	99.95%
2,4,5-TP (Silvex)*	99%	0.270	0.0016
TRIBROMOACETIC ACID*		0.042	0.001
1,2,4 TRICHLOROBTADIENE (Unsymtrichlorobenzene)*	>99%	0.160	0.0005
1,1,1-TRICHLOROETHANE (1,1,1-TCA)*	95%	0.084	0.0046
1,1,2-TRICHLOROETHANE*	>99%	0.150	0.0005
TRICHLOROETHYLENE (TCE)*	>99%	0.180	0.0010
TRIHALOMETHANES (TTHM) (Chloroform; Bromoform; Bromodichloromethane; Dibromochloromethane)	>99.8%	0.45 +/- 20%	0.080
TURBIDITY	>99%	11 +/- NTU	0.5 NTU
Unsym-Trichlorobenzene (see 1,2,4-TRICHLOROBTADIENE)*	>99%	0.160	0.0005
Vinylbenzene (see STYRENE)*	>99%	0.150	0.0005
XYLENES (TOTAL)*	>99%	0.070	0.001

Note: This addresses the U.S. Environmental Protection Agency (USEPA) Primary and Secondary Drinking Water Regulations in effect at its time of publication, as they related to Multi-Pure's performance in conformance to the industry performance criteria. These regulations are continually being updated at the Federal level. Accordingly, this list of MCLs will be reviewed and amended when appropriate. Please see sales brochure for list of product certifications.

NSF/ANSI 42 Aesthetic Effects

The systems have been tested according to NSF/ANSI Standard No. 42 for the reduction of the following substances. The concentration of the indicated substances in water entering the system was reduced to a concentration less than or equal to the permissible limit for water leaving the system.

Substance	Percent Reduction**	Influent challenge concentration	Maximum permissible product water concentration
CHLORAMINE as Aesthetic Effect (As Monochloramine)	>98.3%	3.0 mg/L +/- 10%	0.5 mg/L
CHLORINE as Aesthetic Effect	99%	2.0 Mg/L +/- 10%	> or = 75%*
PARTICULATE , (Nominal Particulate Reduction, Class I, Particles 0.5 TO <1 UM)	Class I > 99%	At Least 10,000 particles/mL	> or = 85%*

FOOTNOTES:

1. Multi-Pure Drinking Water Systems have been certified, as indicated, by NSF International for compliance to NSF/ANSI Standard Nos. 42 and 53.
2. The Multi-Pure Drinking Water Systems have been certified by the State of California Department of Public Health for the reduction of specific contaminants listed herein.
3. Chloroform was used as a surrogate for claims of reduction of VOCs. Multi-Pure Systems tested at >99.8% actual reduction of Chloroform. Percent reduction shown herein reflects the allowable claims for VOCs as per tables in the Standard.
4. **Do not use with water that is microbiologically unsafe or with water of unknown quality without adequate disinfection before or after the unit. Systems certified for cyst reduction may be used on disinfected waters that may contain filterable cysts.**
5. Filter life will vary in proportion to the amount of water used and the level of impurities in the water being processed. For optimum performance and to maintain your warranty, it is essential that the filter be replaced when the first of the following occurs: (a) annually; (b) when the unit's rated capacity is reached; (c) the flow rate diminishes; (d) the filter becomes saturated with bad tastes and odors.
6. Model Nos. CB-As-SB-PID and CB-As-PB-PID include a capacity monitor that automatically flashes a yellow light when it is time to replace your filter.
7. Multi-Pure Drinking Water System housings are warranted for a lifetime; all exterior hoses and attachments to the System are warranted for one year. Please see the Owner's Manual for complete product guarantee and warranty information.
8. Please see the Owner's Manual for installation instructions and operating procedures.
9. In compliance with New York law, it is recommended that before purchasing a water treatment system, NY residents have their water supply tested to determine their actual water treatment needs. Please compare the capabilities of the Multi-Pure unit with your actual water treatment needs.
10. While testing was performed under standard laboratory conditions, actual performance may vary.
11. The list of substances which the treatment device reduces does not necessarily mean that these substances are present in your tap water.

Operational Specifications

<u>CB-As-SX series</u>	
Replacement Filter Type	CBTAs
Approximate Filter Capacity	600 gallons/960 gallons*
Approximate Flow Rate @ 60 psi	1.0 gpm
Maximum Working Pressure	100 psi/ 8.8 kg/cm ²
Minimum Working Pressure	30 psi/ 2.1 kg/cm ²
Maximum Operating Temperature	100°F/38°C for cold water use only
Minimum Operating Temperature	32°F/0°C
* with end-of-life indicator (PID)	



CB-As-SB

XI Troubleshooting and Questions and Answers

PROBLEM	CAUSE	REMEDY
Taste/Odor (general)	The carbon block filter may become saturated with the taste and odors it adsorbs.	Change the filter
Rotten egg odor	Typically a sign of H ₂ S (hydrogen sulfide) gas which can occur at any time.	It is recommended that you keep two filter cartridges on hand. When one becomes saturated with odor, remove it and allow it to dry upside (threaded-hole) down on a paper towel. The sulfur gas will dissipate, allowing the cartridge to be reused. Rotating cartridges in this manner will, in some cases, help extend the life of the filter.
Odor & odd color on cartridge	H ₂ S (hydrogen sulfide) caused by iron (orange/brownish), manganese (blackish), and/or decaying organisms (slimy/blotchy colors) can cause rotten egg-type odor.	Change of filter cartridge is the only recommended course of action.
“Milky” color in water	Higher than normal water pressure through the System will create small bubbles. Air bubbles do not effect the performance of the system. Air can be trapped inside the lid of the housing.	For a countertop installation, turn on the water and engage the diverter valve while reducing the water flow slightly. For a below the sink installation, adjust the water pressure at the feedwater adapter below the sink. Turn on the ledge faucet or diverter valve and let water run for 3 to 5 minutes after installation or filter change.
Flow rate is slow	Solids: The filter is designed to become restricted in its flow rate when the filter becomes clogged with particulate and other contaminants. When your water flow rate slows to the point that it is inconvenient to use, it is time to change your filter.	It is recommended that filters be replaced at least every twelve months or when its capacity is reached, whichever comes first. If water pressure is too low, adjust water pressure to 60 psi. If other faucets or sprinklers are on turn off other running water.

Maintenance Problems

Flushing/disinfecting the unit housing: Multi-Pure recommends that you not allow water to sit in a unit for extended periods of time without it being used. If a unit is left unused for more than 10 days, it may need to be flushed/disinfected before you resume use.

To flush a unit that may be contaminated:

1. Confirm that water is turned off to the unit.
2. Relieve the water pressure (if below sink unit) by opening the unit faucet.
3. Remove and discard the used filter.
4. Clean & rinse out the inside of the housing.
5. Add 5 to 7 drops of bleach, such as Clorox™ or Purex™ (5 ¼% sodium hypochlorite) to the bottom canister.
6. Reconnect the housing top and bottom without the replacement filter.
7. Turn on water and let unit housing fill up with the water/bleach solution.
8. Allow unit to soak for at least 30 minutes.
 - a. Countertop Units: To disinfect the spout, place your finger over the tip of the spout and turn the unit upside down. Repeat this procedure 2 or 3 times during the 30-minute soak period.
 - b. Below Sink Units: To disinfect the faucet spout, remove the spout and place it in a container with one-quart of water and bleach (use 5 drops of bleach) and allow to soak for 30 minutes.
9. After the housing has soaked for 30 minutes, disassemble the top and bottom and pour out the water/bleach solution. Rinse out the inside of the housing.
10. Replace the filter (cartridge) following the instructions with the new filter.
11. Follow the instructions with the replacement filter for reconnecting and flushing your unit.

Questions and Answers (continued)

QUESTION	ANSWER	COMMENTS
When should you replace your filter cartridge?	The rated capacity of the replacement filter is shown in Section I.B, Operating and Maintenance. It is recommended that filters be replaced annually or when the capacity is reached, whichever occurs first.	Filter life will vary in proportion to the amount of water used and the type and level of impurities in the water being processed.
How do I obtain a replacement filter?	You may order replacement filters from your local water treatment dealer.	N/A
Will low pH or acid water affect the Multi-Pure filter?	No.	Mineral components expressed as acidity and alkalinity determine pH. Neutrality is 7; below 7 is acidity; above 7 is alkalinity.
Does deionized water or soft water have any affect on Multi-Pure water?	No.	N/A
Can the Multi-Pure System be connected to an automatic ice-maker?	The below sink models can be connected to both your sink and refrigerator, to any type of water dispenser or ice-maker. You can use the same unit installed under your sink to also filter the water at your refrigerator.	To connect a single Drinking Water System to both your sink and refrigerator, request an "ice-maker tee" on the order form.
Can the Multi-Pure System be used during an emergency or when the water is turned off?	Yes, you can hand pump or siphon water through the Multi-Pure System during an emergency. CAUTION --the Multi-Pure System is not intended to be used where the water is microbiologically unsafe or with water of unknown quality without adequate disinfection before or after the unit.	If water source is questionably contaminated, it should be disinfected prior to use. Add ¼ tsp of household bleach per gallon of water; the Multi-Pure System will remove this solution from the water. Hand pump kits are available from Multi-Pure.
What causes "white" particles to appear in Multi-Pure water when it is frozen or boiled:	The natural minerals in the Multi-Pure water solidify when the water is frozen, and those minerals appear as white flakes or specks when the ice melts.	Natural minerals are beneficial to good health and their existence in drinking water (in normal quantities) should not cause any alarm. Minerals can be removed by Reverse Osmosis technology, which may also be available from your dealer on request.
Why does the Multi-Pure System reduce Volatile Organic Chemicals, but not natural minerals?	Minerals are totally dissolved in solution and do not have an actual physical size; thus, the minerals pass through the filter unchanged.	The materials used in Multi-Pure Drinking Water Systems are specially selected for their ability to react with the chemicals in the water, but not with natural minerals that are beneficial to good health.
Should sediment be removed with a standard filter first?	In areas with excessive sedimentation, prefiltration will help extend the operational efficiency of the Multi-Pure cartridge; however, in most areas this is not necessary.	The Multi-Pure System contains a triple filter. The outside material is a prefilter that helps protect the solid carbon block surface from prematurely clogging with large sediment.
Why is the compressed activated carbon block filtration system more efficient than activated carbon (loose granular) systems?	Multi-Pure's solid carbon block filters are compacted into a dense structure causing every molecule of water to be forced through microscopic pores of carbon, effectively reducing a wide range of contaminants of health concern (see Section 3), as well as adsorbing tastes and odors and removing particulate matter removed by typical activated carbon filters.	The Water Quality Association reports that "an activated carbon filter can reduce organics and solid particles, as well as offensive tastes and odors." Only precoat and solid carbon block filters are engineered to provide 0.5 micron mechanical filtration with efficient adsorption on very fine sized activated carbon particles."
What is the difference between a "water softener" and the Multi-Pure Drinking Water System?	Softeners are not used to treat drinking water; they are used only to change the water hardness. Softeners put sodium into the water in exchange for magnesium or calcium ions. Multi-Pure Drinking Water Systems do not remove dissolved minerals, so, the pH is not changed. Natural minerals most often found in water are considered to be essential to good health.	Soft water is good for bathing and laundering and may extend the life of hot water heaters and boilers. However, soft water should not be used for watering plants or lawns. It is recommended that you bypass a water softener when installing your Multi-Pure Drinking Water System.
Can the Multi-Pure System be used on untreated water?	If water source is questionable, it should be disinfected prior to use. Add ¼ tsp of household bleach per gallon of water; the Multi-Pure System will remove this solution from the water. Consult your nearest public water utility for assistance or guidelines on proper treatment of untreated water.	Multi-Pure Systems are designed to be used on treated water systems; they are not intended to be used where the water is microbiologically unsafe or with water of unknown quality without adequate disinfection before or after the unit. Systems certified for cyst reduction may be used on disinfected waters that may contain filterable cysts.

If you have any questions regarding the installation of your Multi-Pure Drinking Water System or for replacement filters,

Please call your authorized dealer:

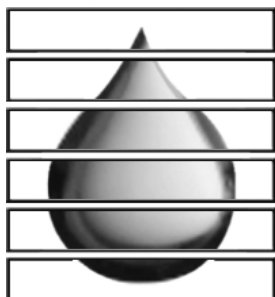
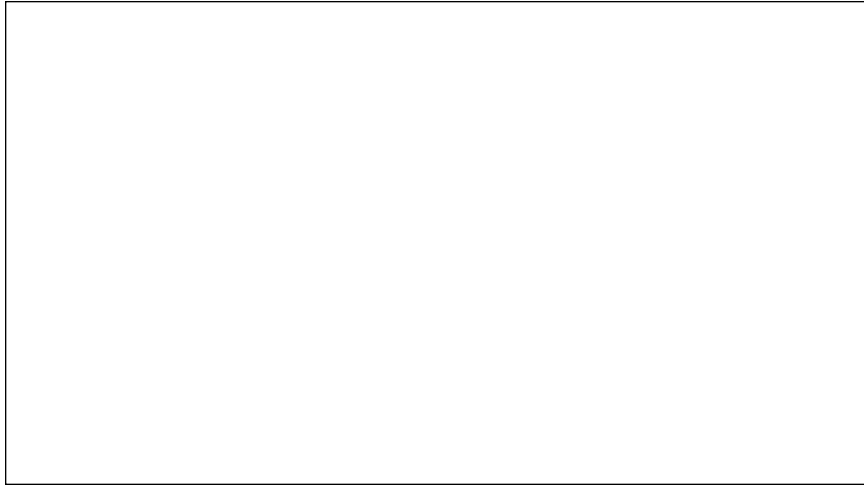

MULTI-PURE®

F508CB/1006